

**PICS GLOBAL
POLARGY INTEGRATED CEILING SYSTEM**



LAST MODIFIED
January 31, 2023

TITLE
ISO COVER

PROJECT NAME
**PICS GLOBAL
Structural Ceiling
Technical Drawing**

01

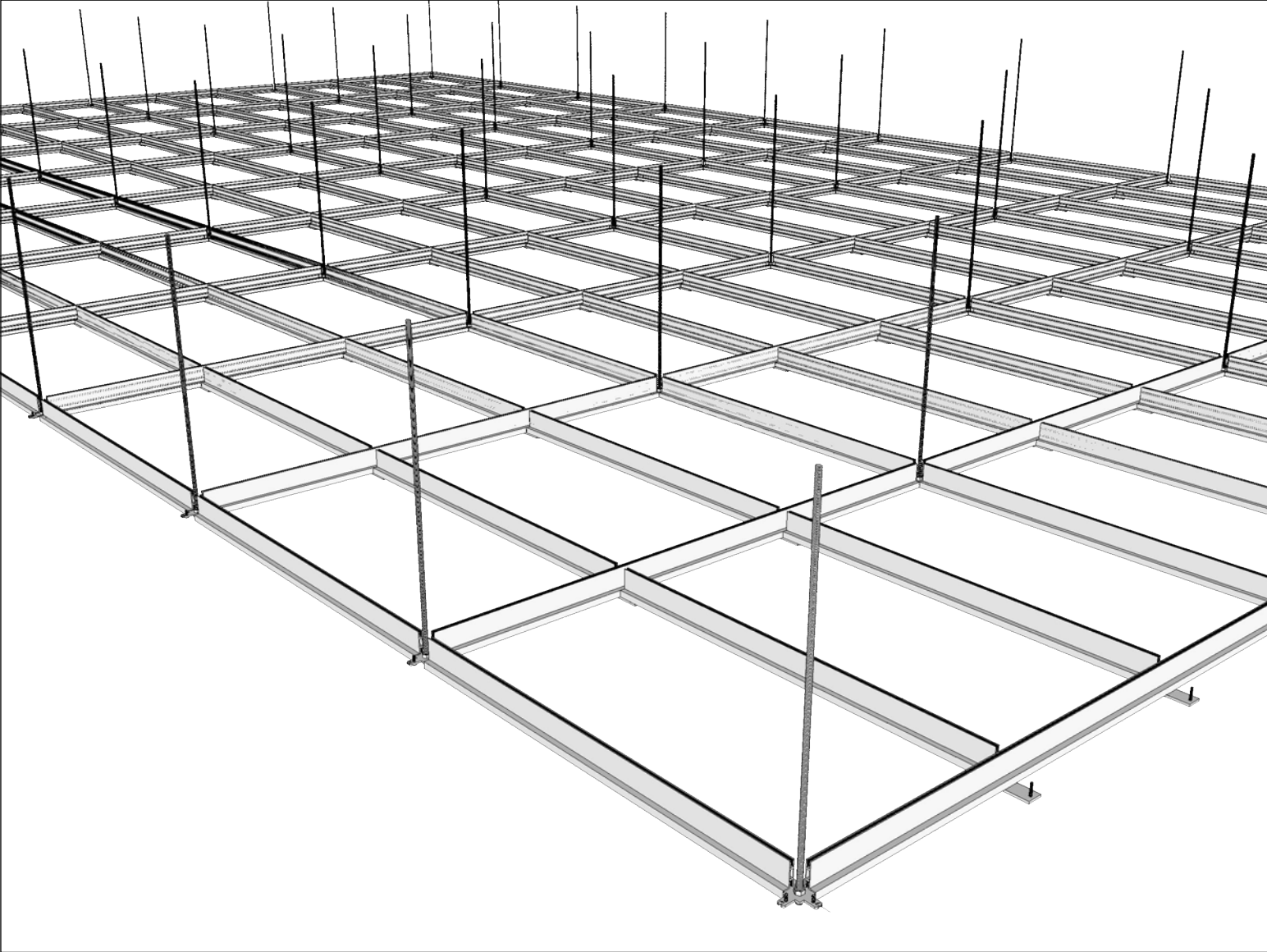

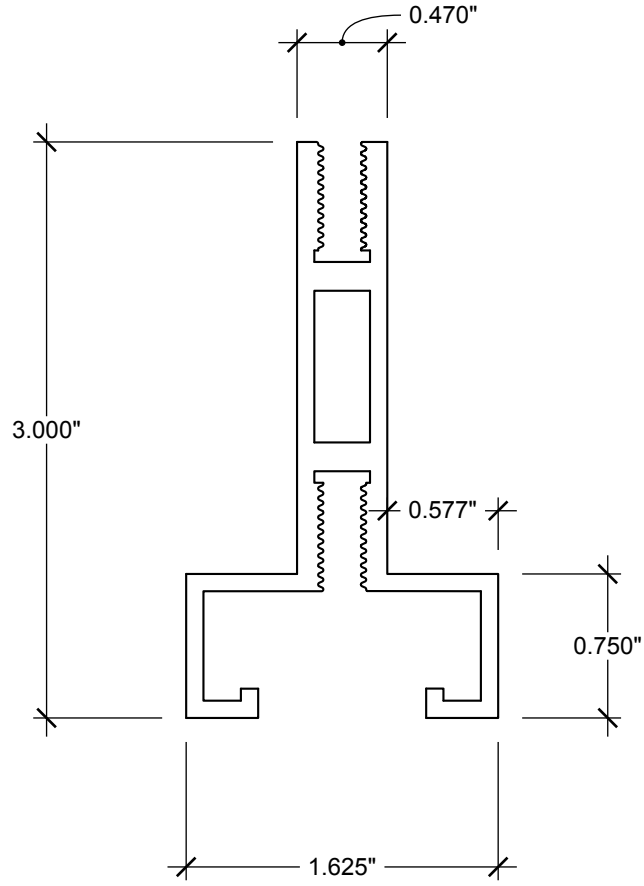

LAST MODIFIED
January 31, 2023

TITLE
PICS GLOBAL EXTRUSION
PROFILE

PROJECT NAME
**PICS GLOBAL
Structural Ceiling
Technical Drawing**

02

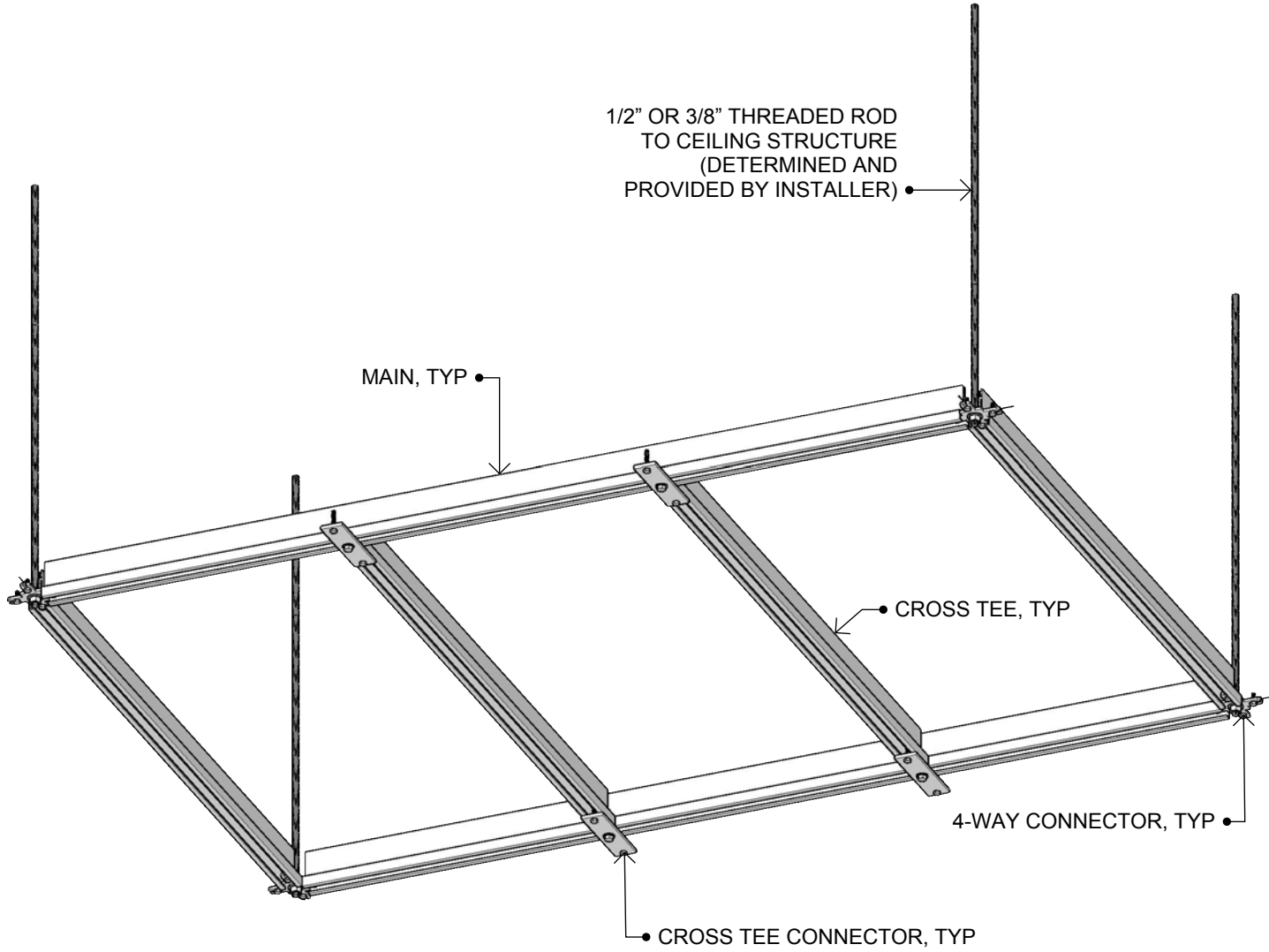

For Seismic Categories A & B

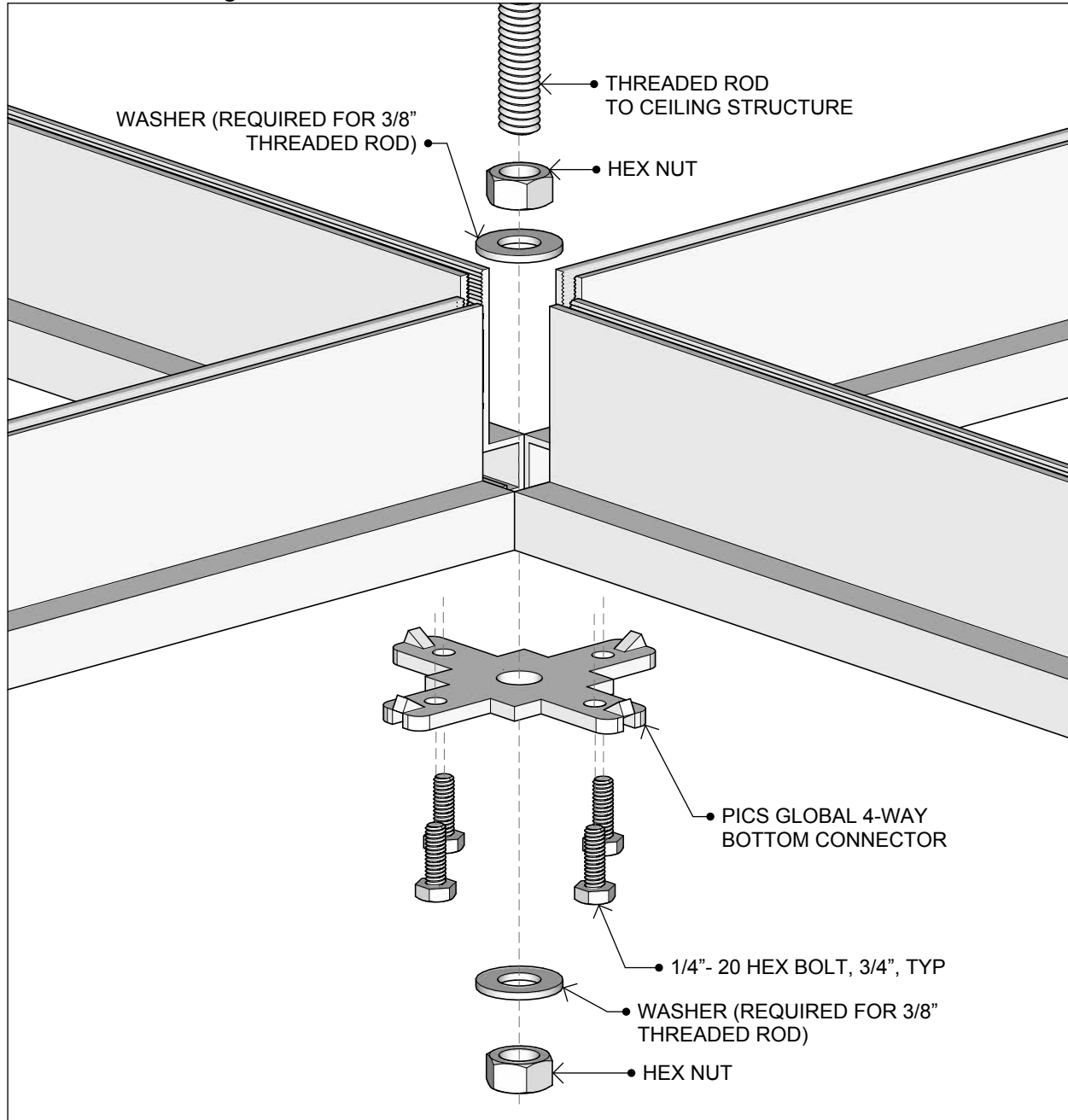

LAST MODIFIED
January 31, 2023

TITLE
4-WAY CONNECTION
EXPLODED

PROJECT NAME
PICS GLOBAL
Structural Ceiling
Technical Drawing

04

For Seismic Categories A & B

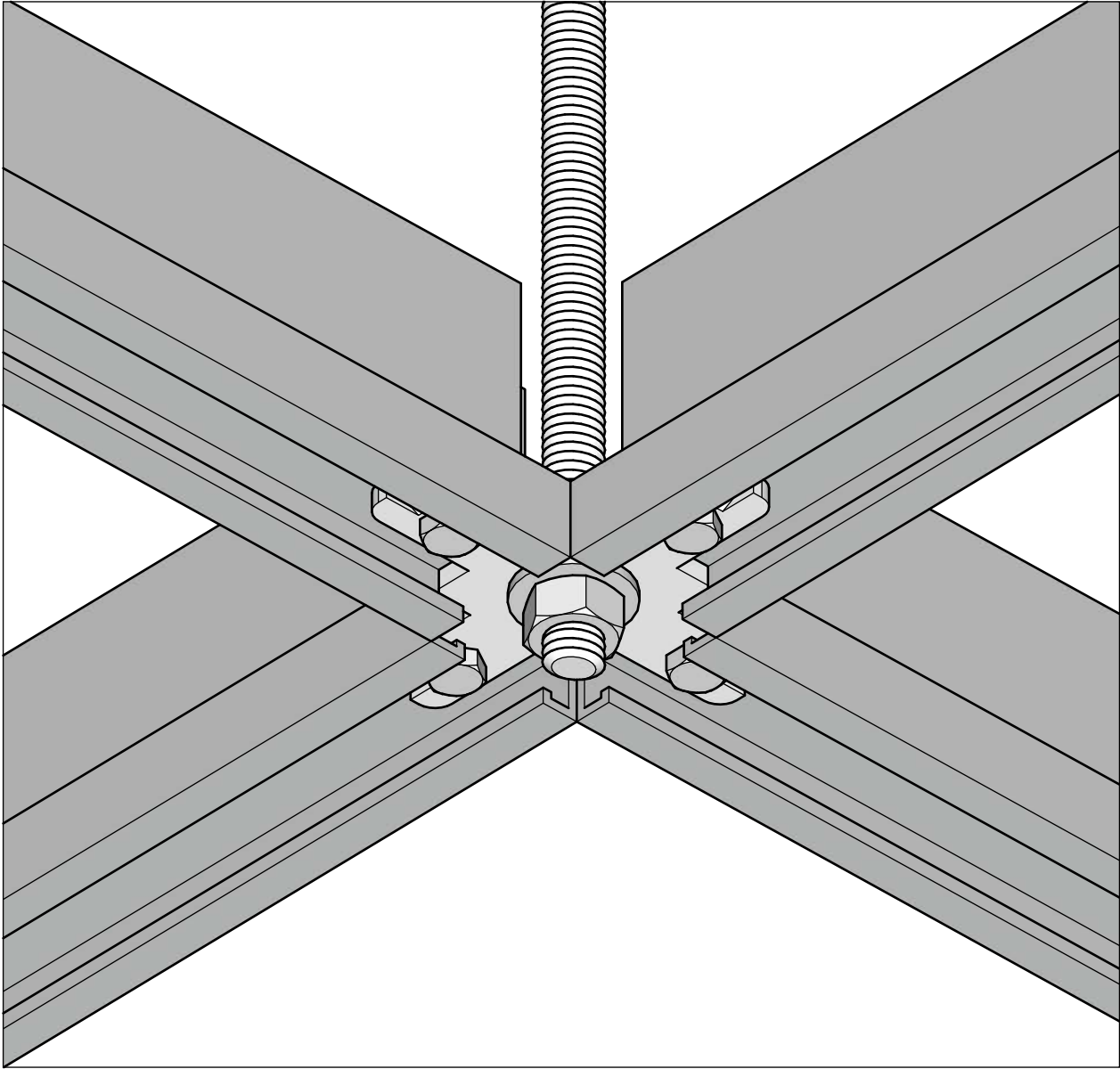

LAST MODIFIED
January 31, 2023

TITLE
4-WAY CONNECTION
BOTTOM ISO

PROJECT NAME
PICS GLOBAL
Structural Ceiling
Technical Drawing

05

For Seismic Categories A & B

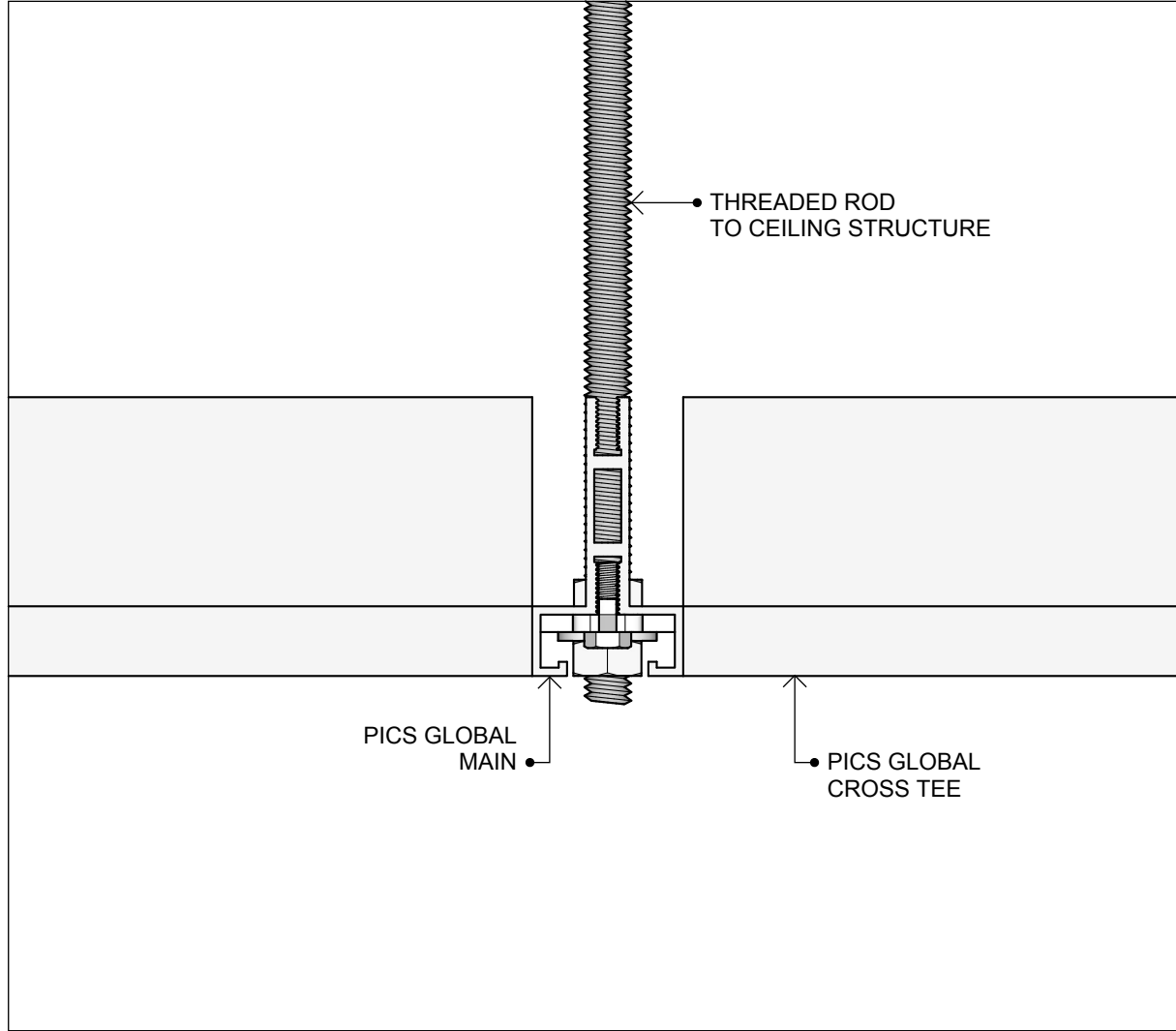

LAST MODIFIED
January 31, 2023

TITLE
4-WAY CONNECTION SIDE

PROJECT NAME
**PICS GLOBAL
Structural Ceiling
Technical Drawing**

06

PATENT PENDING

For Seismic Categories C & D

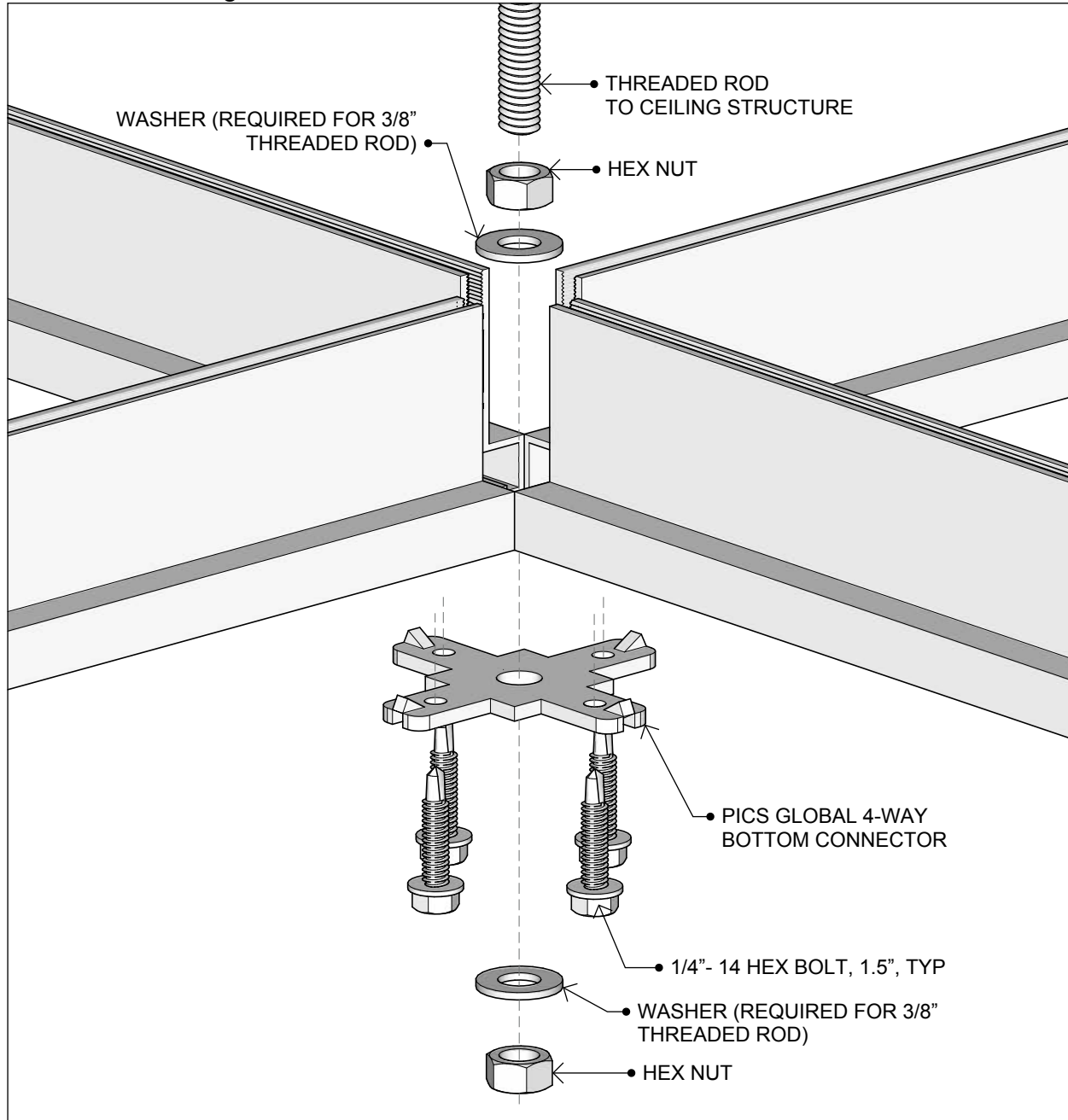

LAST MODIFIED
January 31, 2023

TITLE
4-WAY CONNECTION
EXPLODED SEISMIC

PROJECT NAME
PICS GLOBAL
Structural Ceiling
Technical Drawing

07

For Seismic Categories C & D

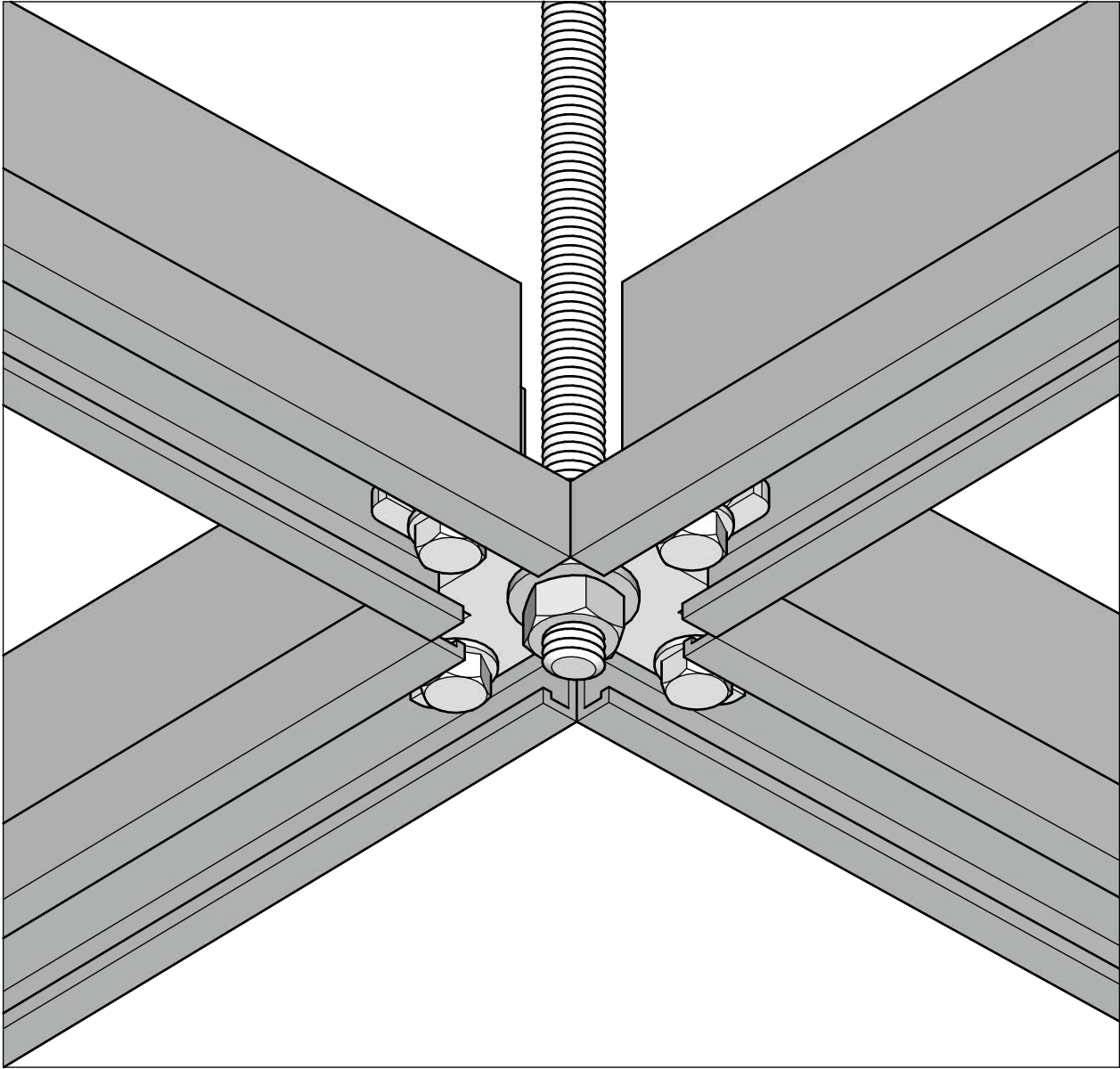

LAST MODIFIED
January 31, 2023

TITLE
4-WAY CONNECTION
BOTTOM ISO SEISMIC

PROJECT NAME
PICS GLOBAL
Structural Ceiling
Technical Drawing

08

PATENT PENDING

For Seismic Categories C & D

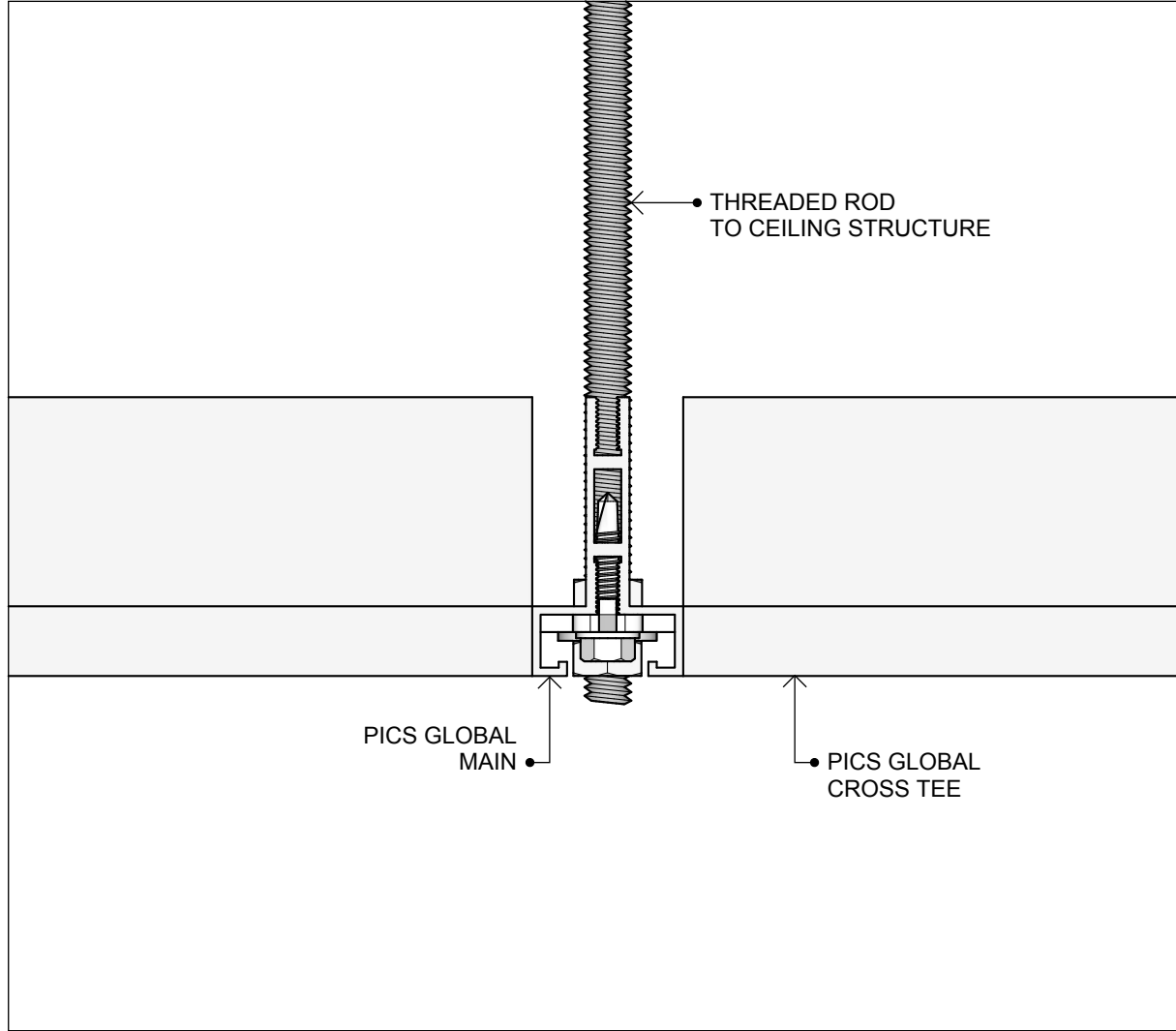

LAST MODIFIED
January 31, 2023

TITLE
4-WAY CONNECTION SIDE
SEISMIC

PROJECT NAME
PICS GLOBAL
Structural Ceiling
Technical Drawing

09

PATENT PENDING

For All Seismic Categories

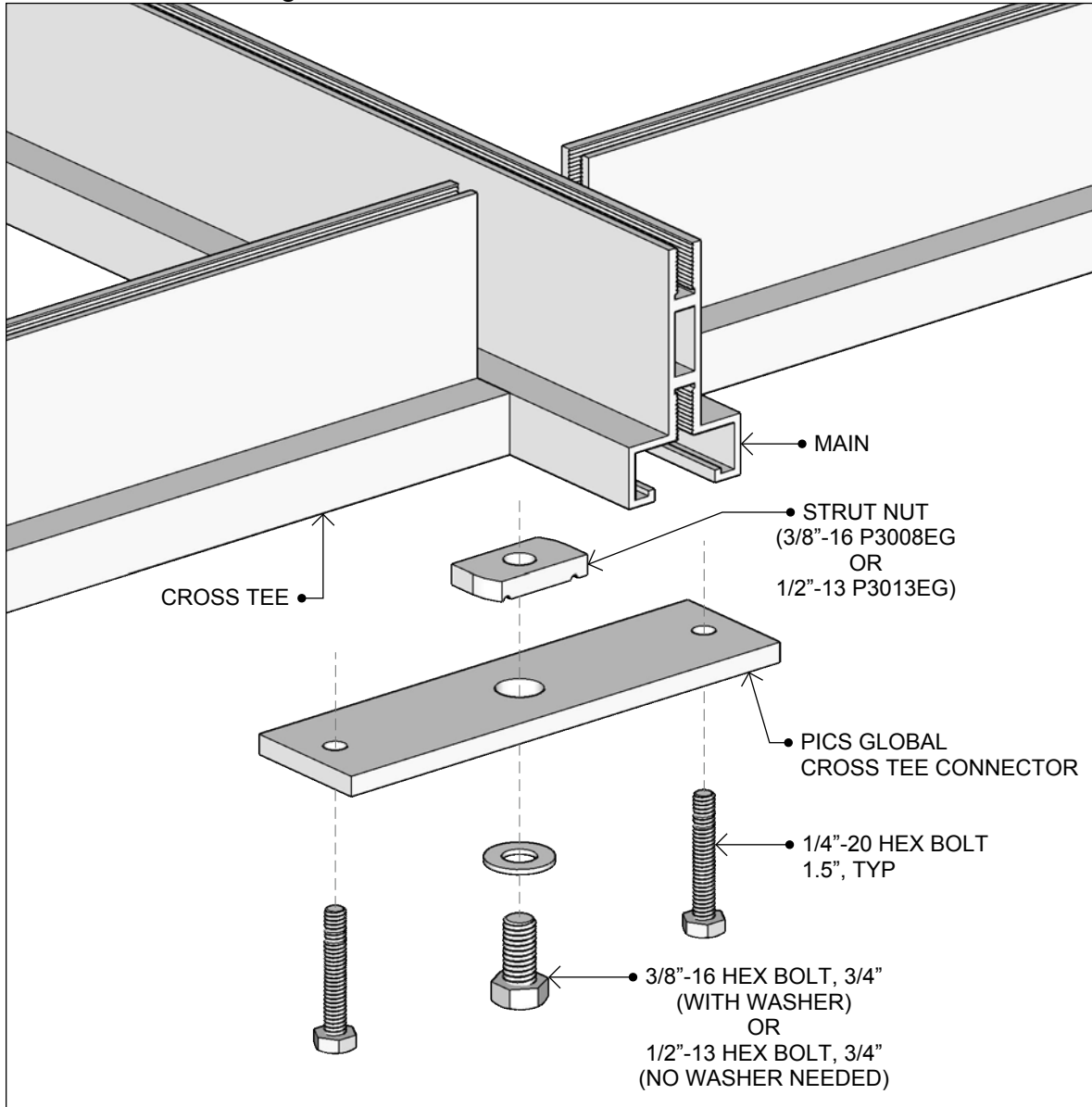

LAST MODIFIED
January 31, 2023

TITLE
CROSS TEE CONNECTION
EXPLODED

PROJECT NAME
**PICS GLOBAL
Structural Ceiling
Technical Drawing**

10

PATENT PENDING

For All Seismic Categories

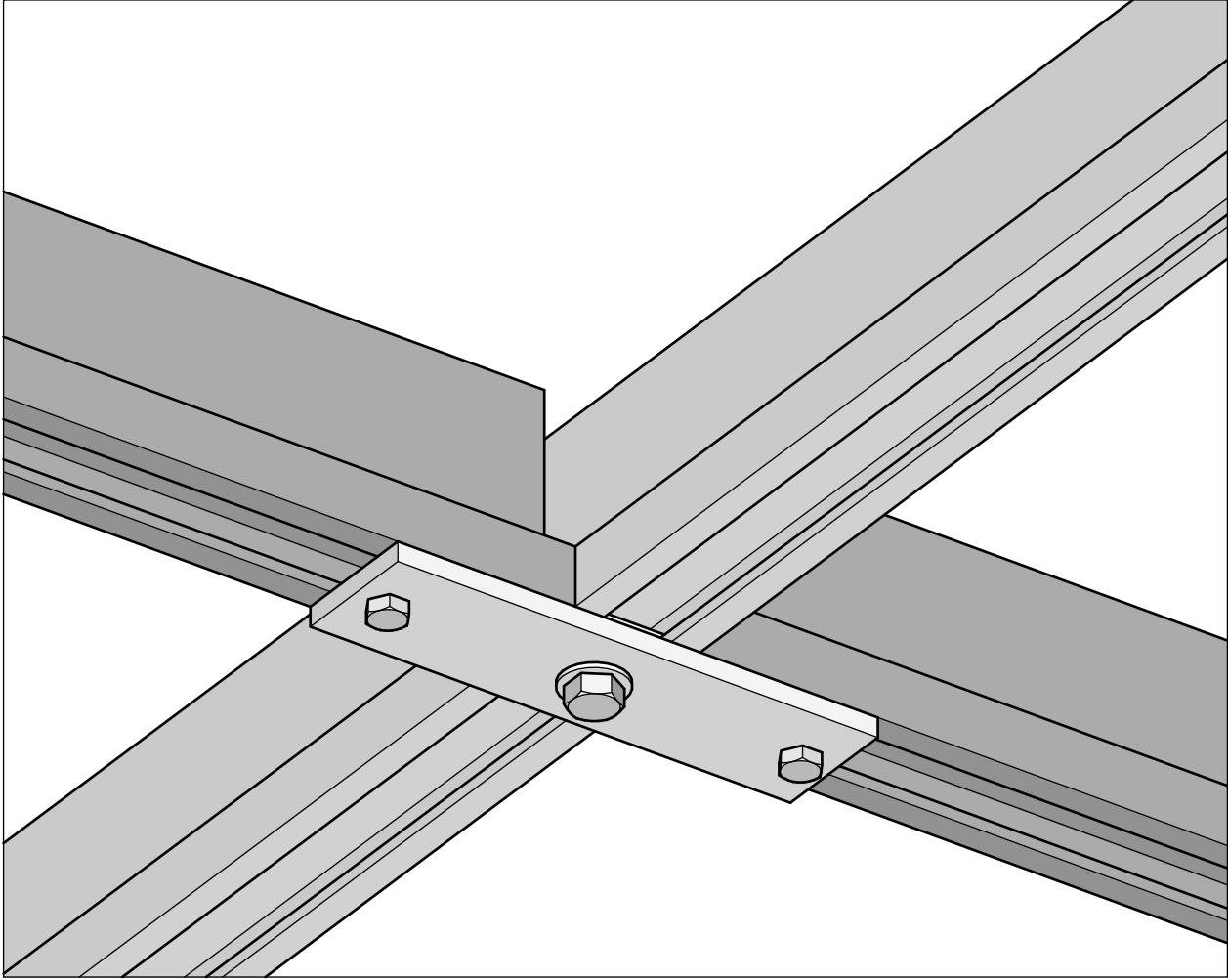

LAST MODIFIED
January 31, 2023

TITLE
CROSS TEE CONNECTION
BOTTOM ISO

PROJECT NAME
PICS GLOBAL
Structural Ceiling
Technical Drawing

11

For All Seismic Categories

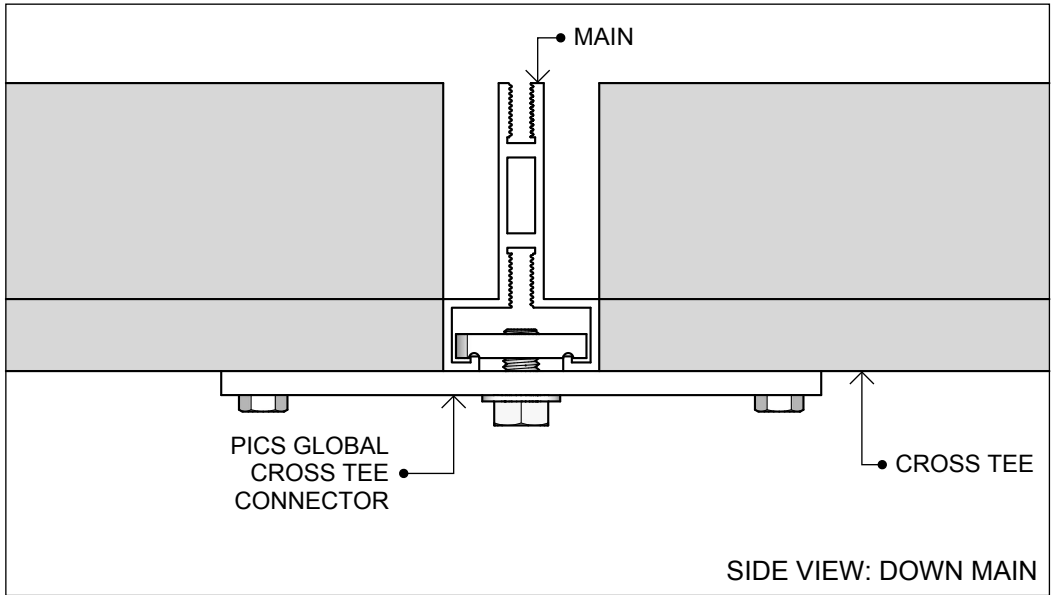
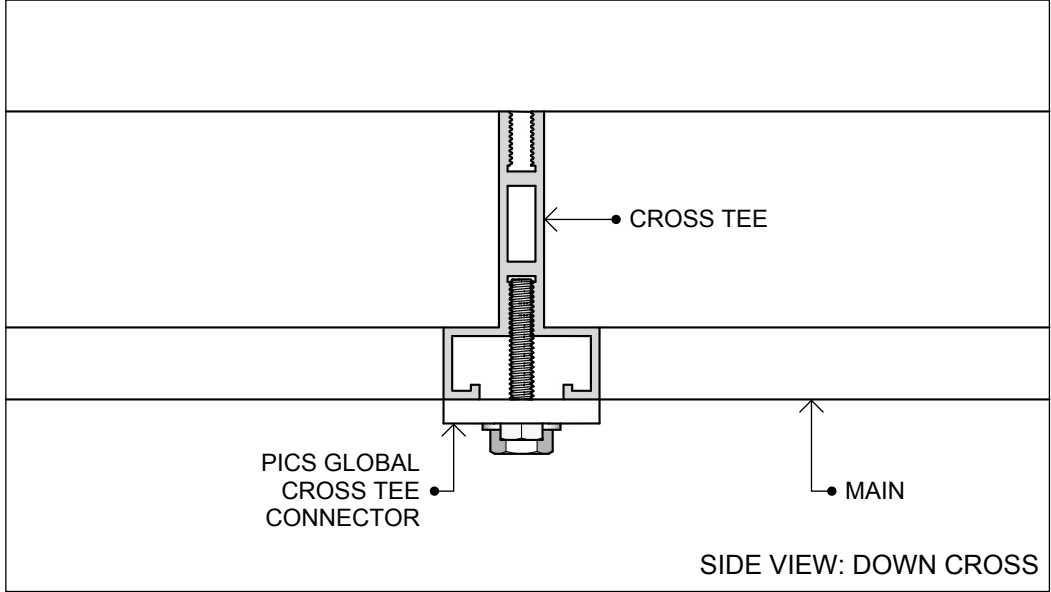

LAST MODIFIED
January 31, 2023

TITLE
CROSS TEE CONNECTION
SIDE VIEWS

PROJECT NAME
**PICS GLOBAL
Structural Ceiling
Technical Drawing**

LITE TEE RESTS ON SURFACE OF MAIN AND HAS ONE SELF-TAPPING SCREW PER SIDE (IN FIELD MAKE SMALL INDENTATION IN CORNER OF TILE ABOVE SCREW SO TILE IS NOT ELEVATED BY SCREW)

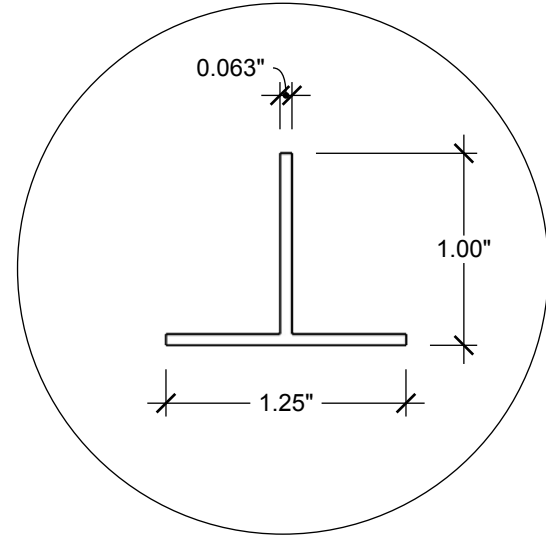
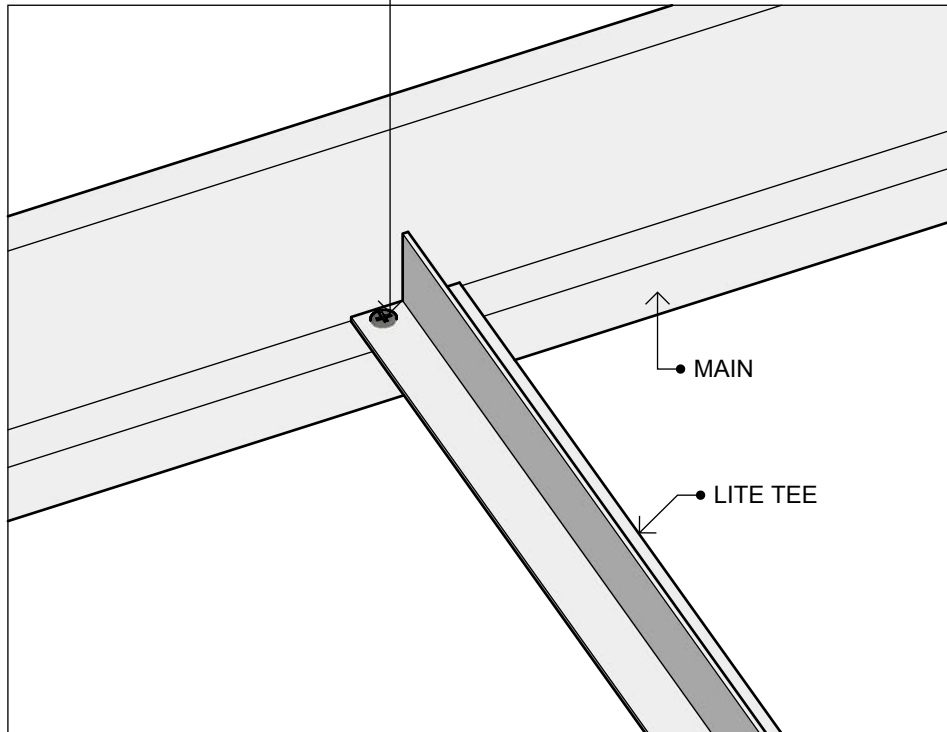

LITE TEE CROSS SECTION DIMENSIONS

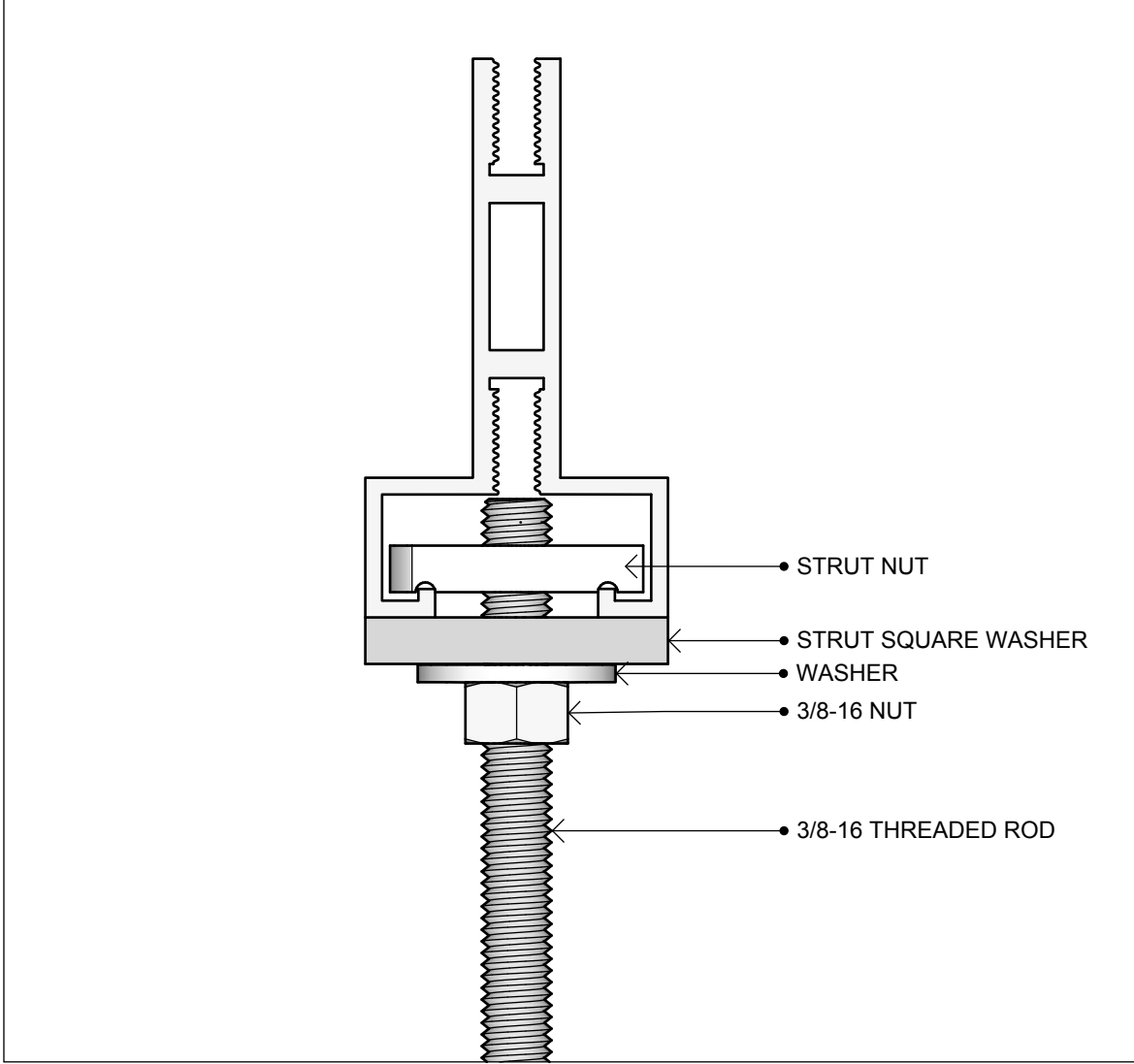

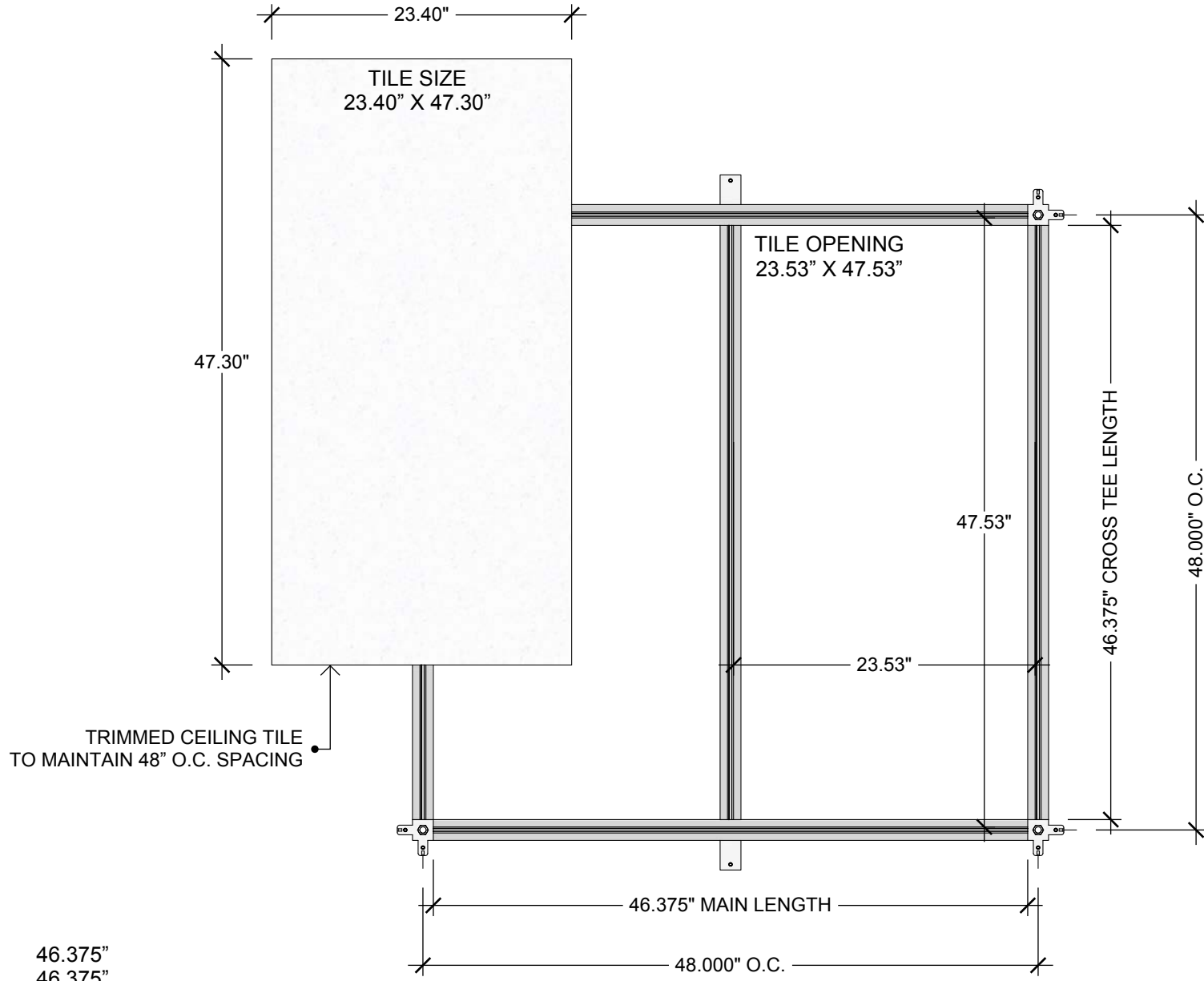

MAIN: 46.375"
CROSS: 46.375"

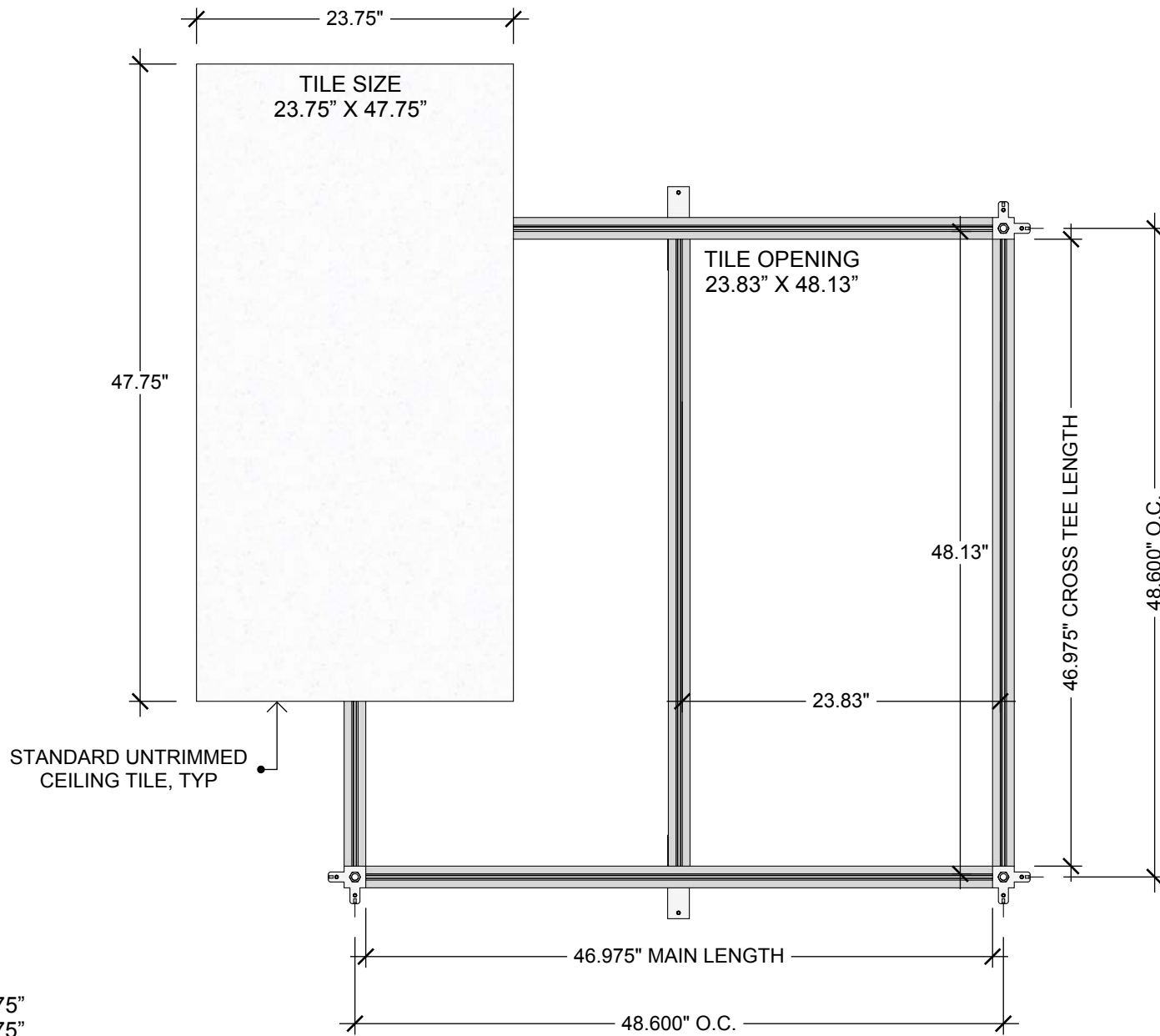

MAIN: 46.975"
CROSS: 46.975"

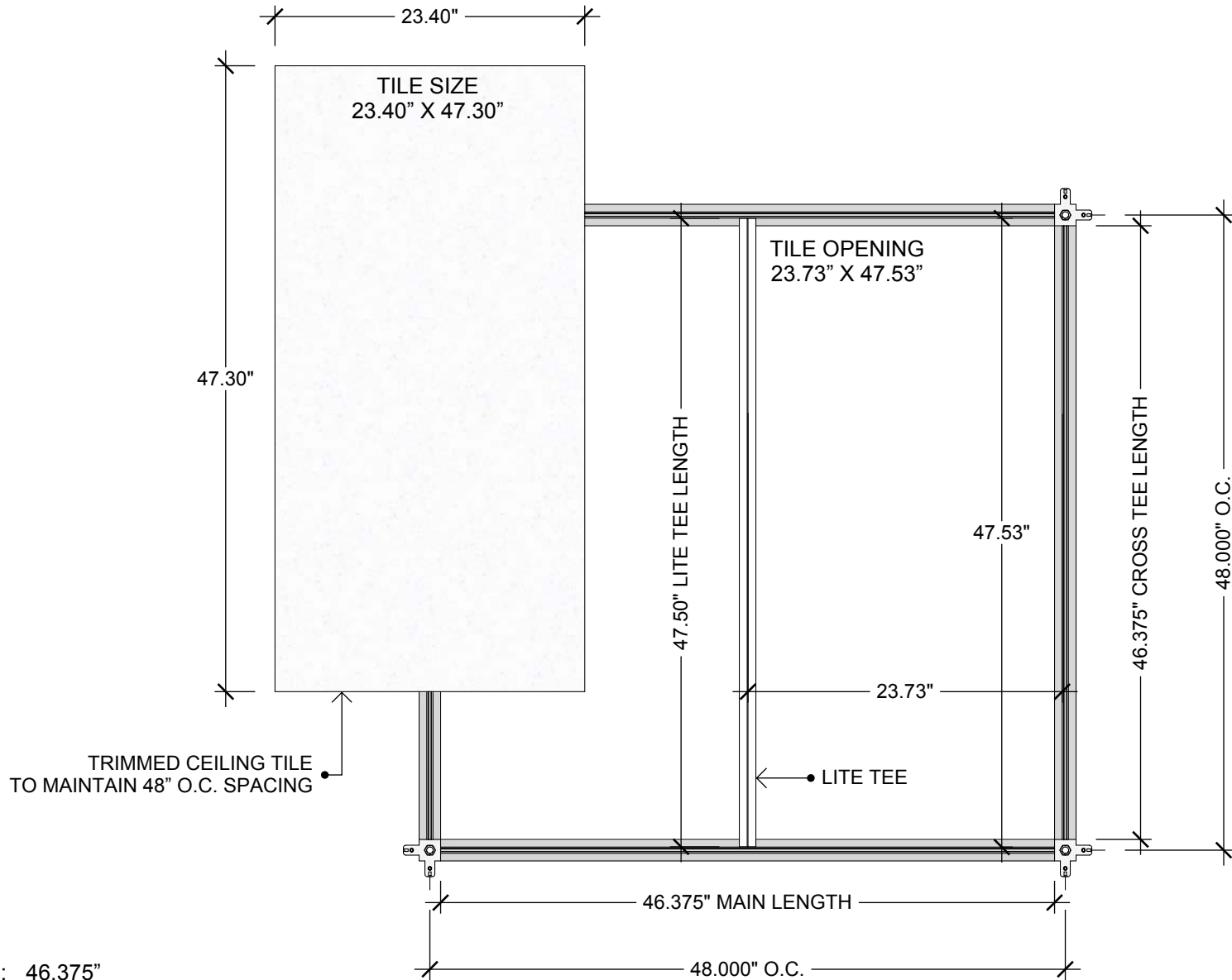

MAIN: 46.375"
CROSS: 46.375"
LITE TEE: 47.50"

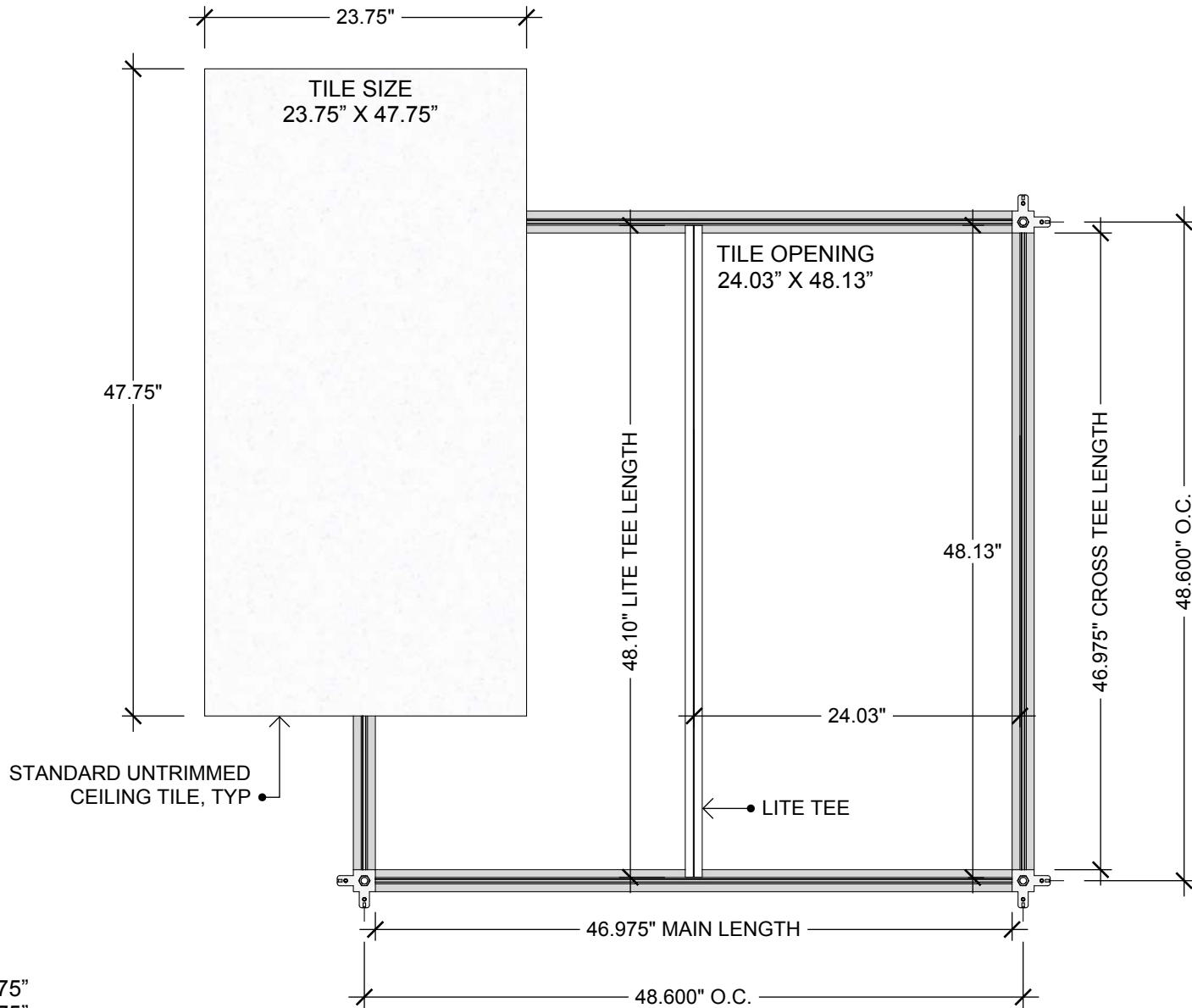

MAIN: 46.975"
CROSS: 46.975"
LITE TEE: 48.10"



LAST MODIFIED
January 31, 2023

TITLE
4' X 4' ROD SUPPORTS
48.0" x 48.0" GRID

PROJECT NAME
PICS GLOBAL
Structural Ceiling
Technical Drawing

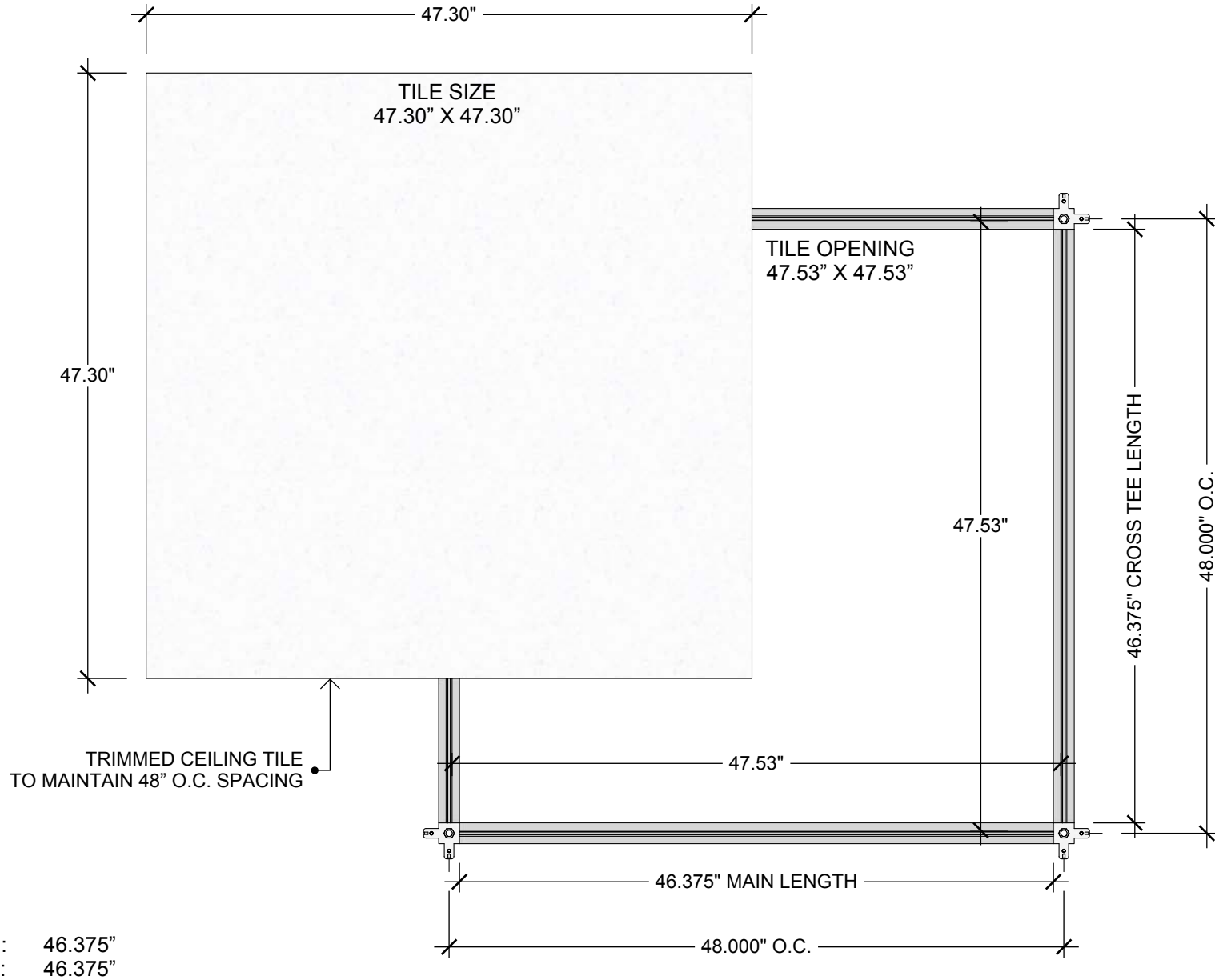

MAIN: 46.375"
CROSS: 46.375"



LAST MODIFIED
January 31, 2023

TITLE
48.6" X 48.6" ROD SUPPORTS
48.6" X 48.6" GRID

PROJECT NAME
PICS GLOBAL
Structural Ceiling
Technical Drawing

20

PATENT PENDING

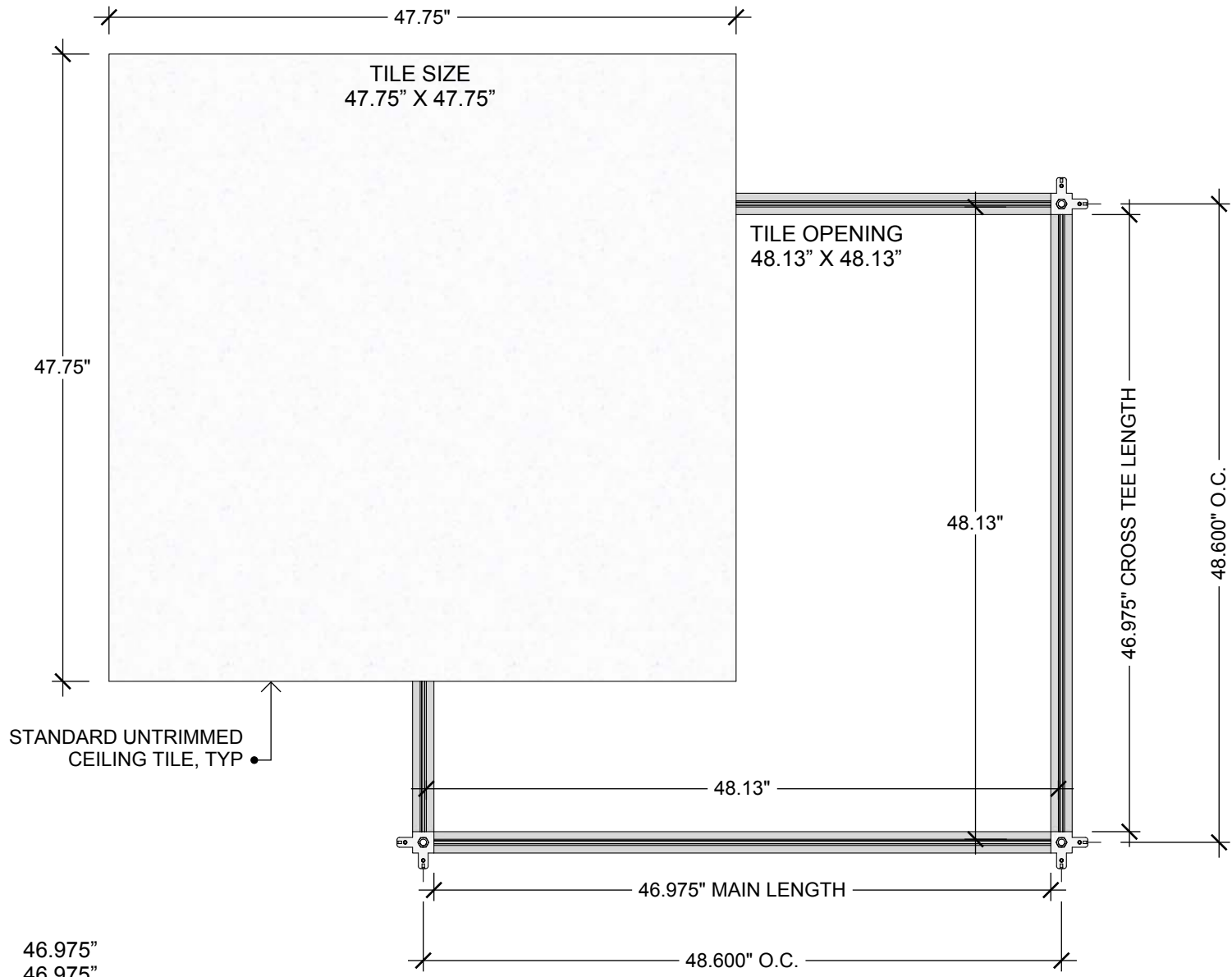

MAIN: 46.975"
CROSS: 46.975"



LAST MODIFIED
January 31, 2023

TITLE
4' X 6' ROD SUPPORTS
WITH TYPICAL CROSS TEE
48.0" / 72.0" ON CENTER

PROJECT NAME
PICS GLOBAL
Structural Ceiling
Technical Drawing

21

PATENT PENDING

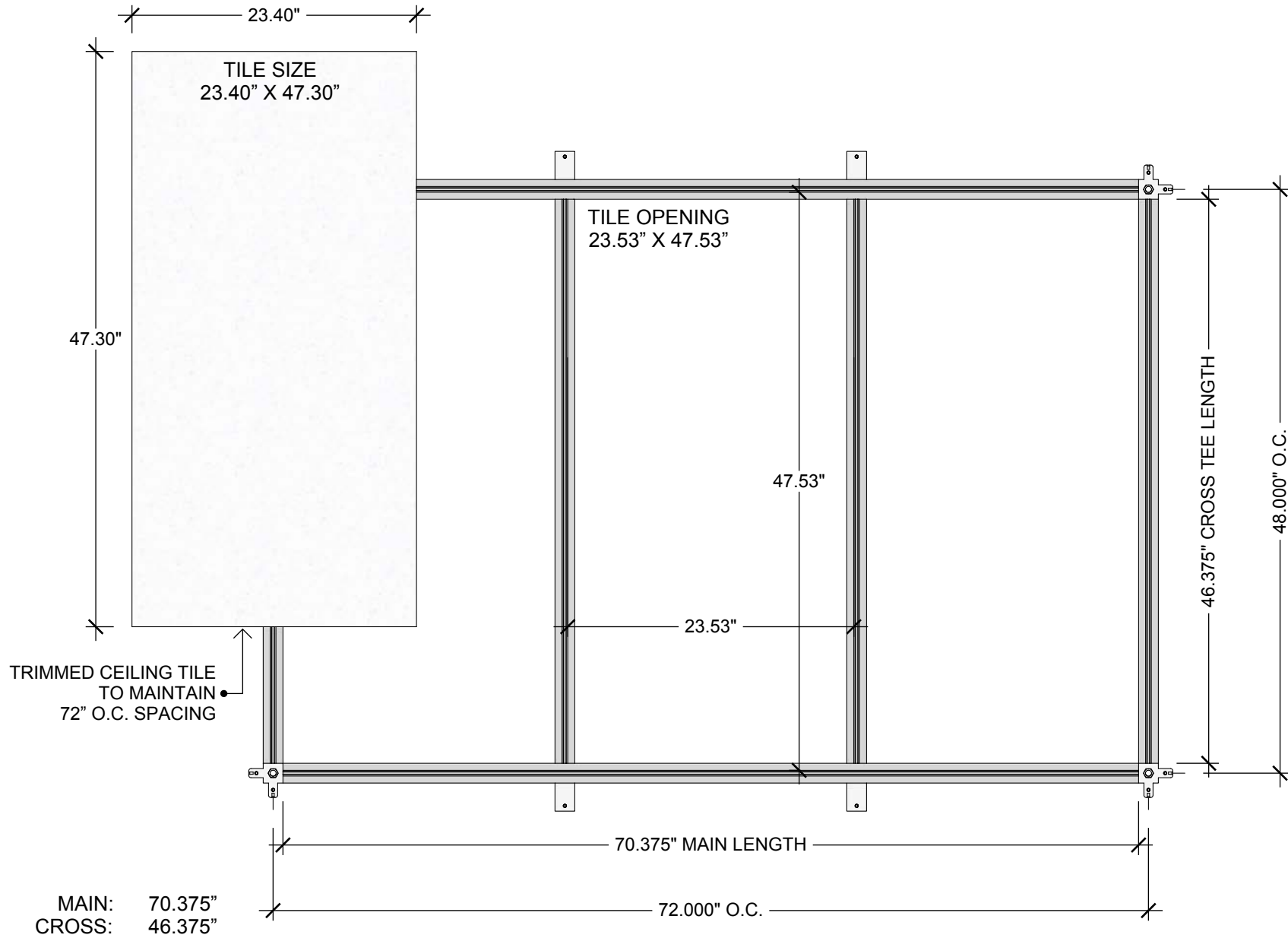



LAST MODIFIED
January 31, 2023

TITLE
48.6" X 73.0" ROD SUPPORTS
WITH TYPICAL CROSS TEE
FOR STANDARD TILES

PROJECT NAME
PICS GLOBAL
Structural Ceiling
Technical Drawing

22

PATENT PENDING

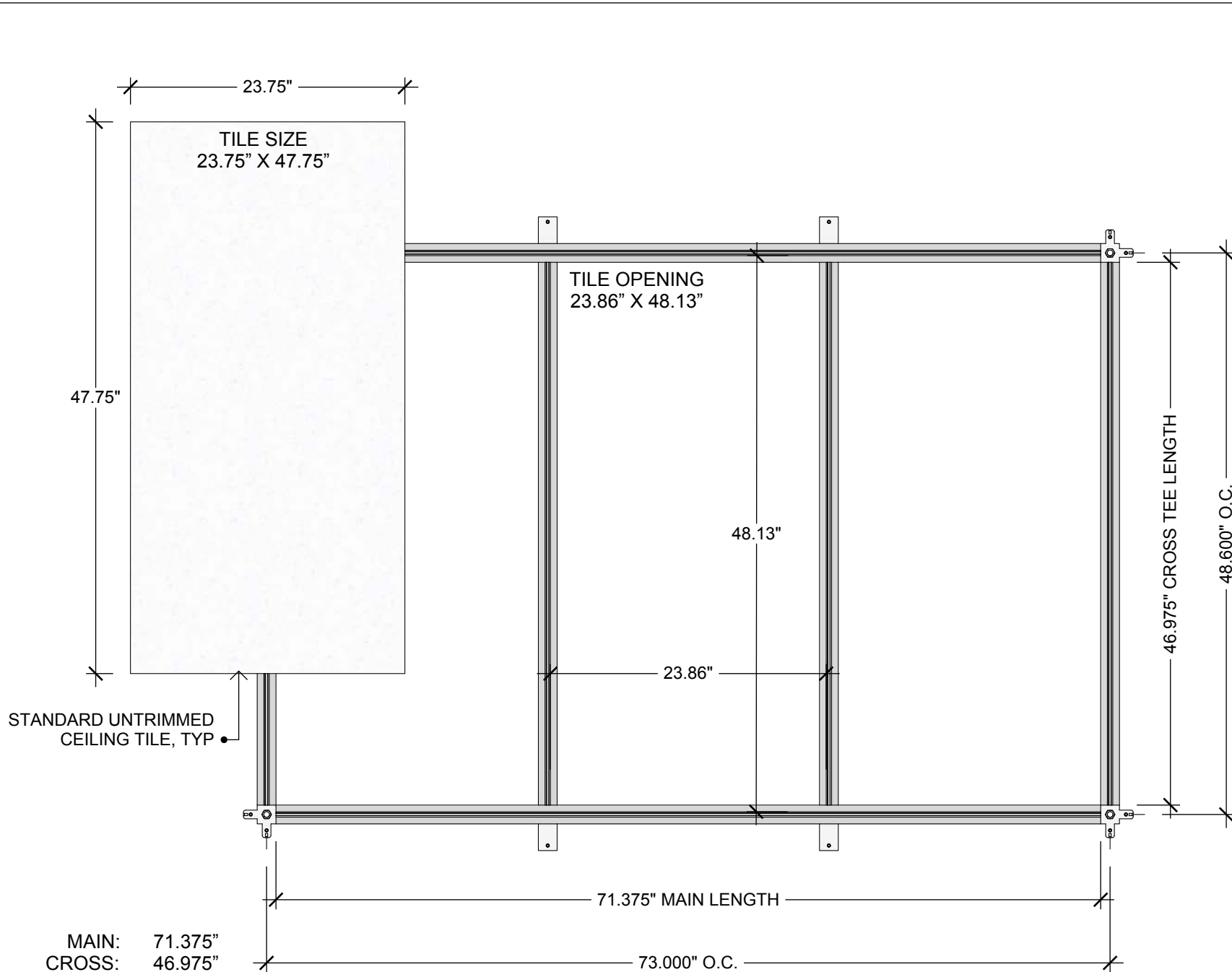



LAST MODIFIED
January 31, 2023

TITLE
4' X 6' ROD SUPPORTS
WITH LITE CROSS TEE
48.0" / 72.0" ON CENTER

PROJECT NAME
PICS GLOBAL
Structural Ceiling
Technical Drawing

23

PATENT PENDING

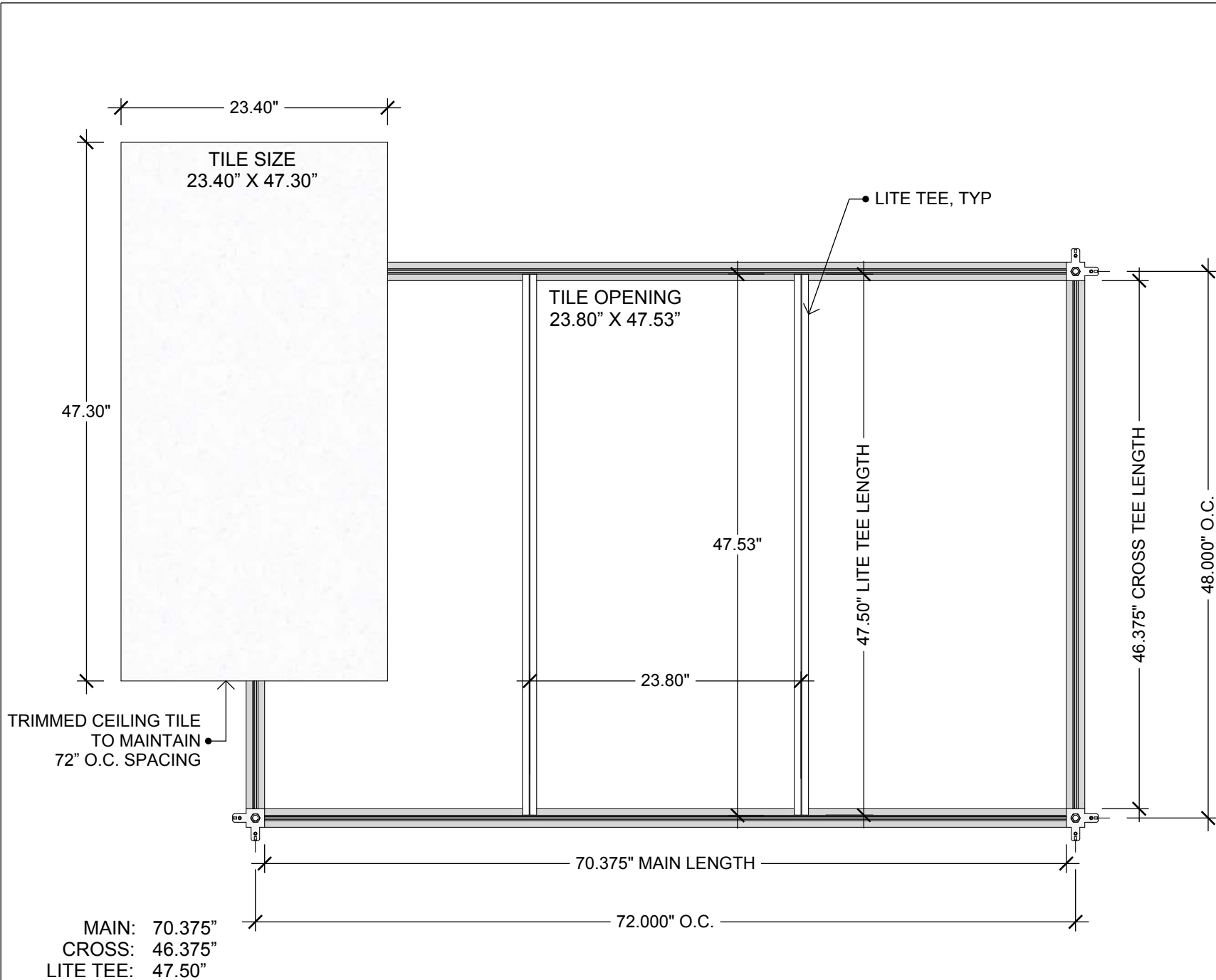



LAST MODIFIED
January 31, 2023

TITLE
48.6" X 73.0" ROD SUPPORTS
WITH LITE CROSS TEE
FOR STANDARD TILES

PROJECT NAME
PICS GLOBAL
Structural Ceiling
Technical Drawing

24

PATENT PENDING

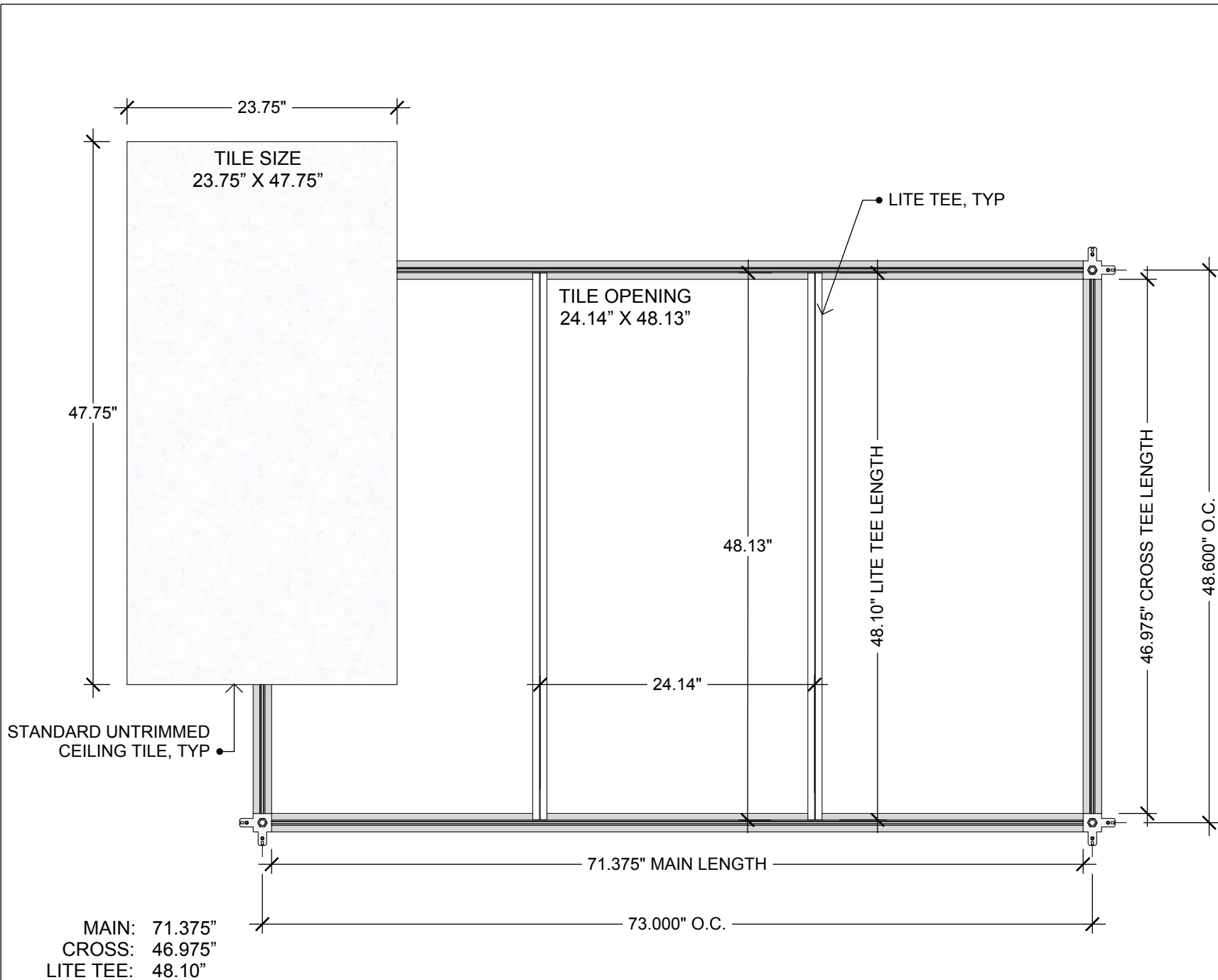

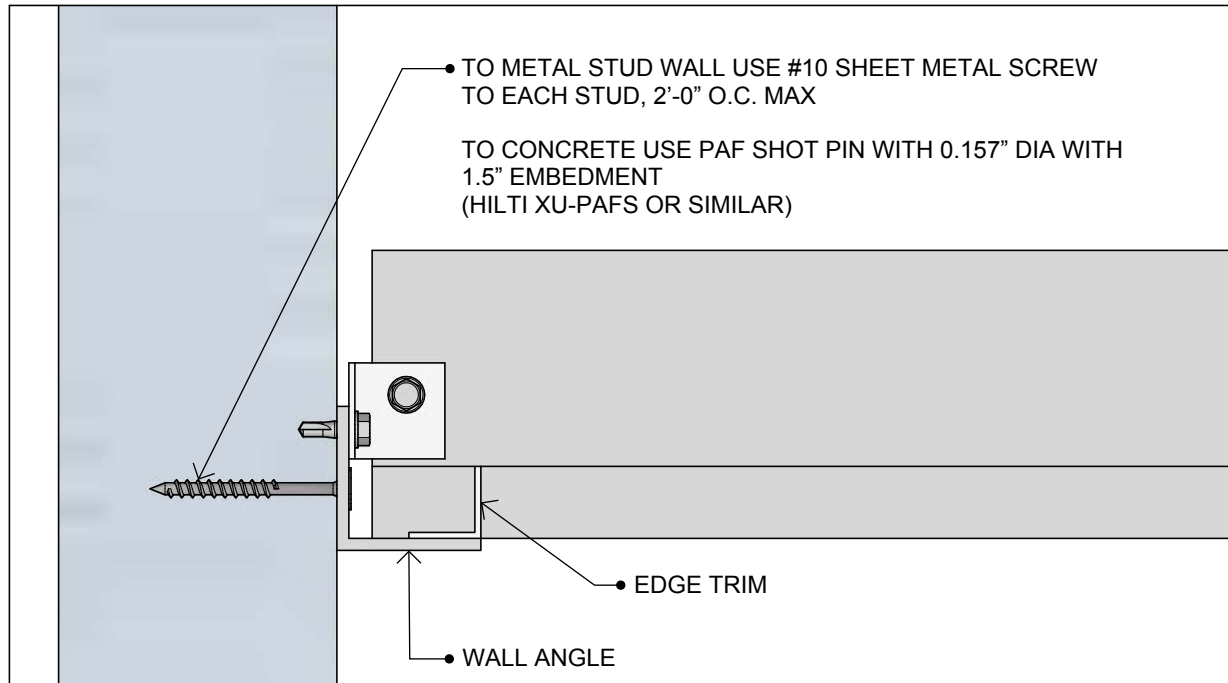
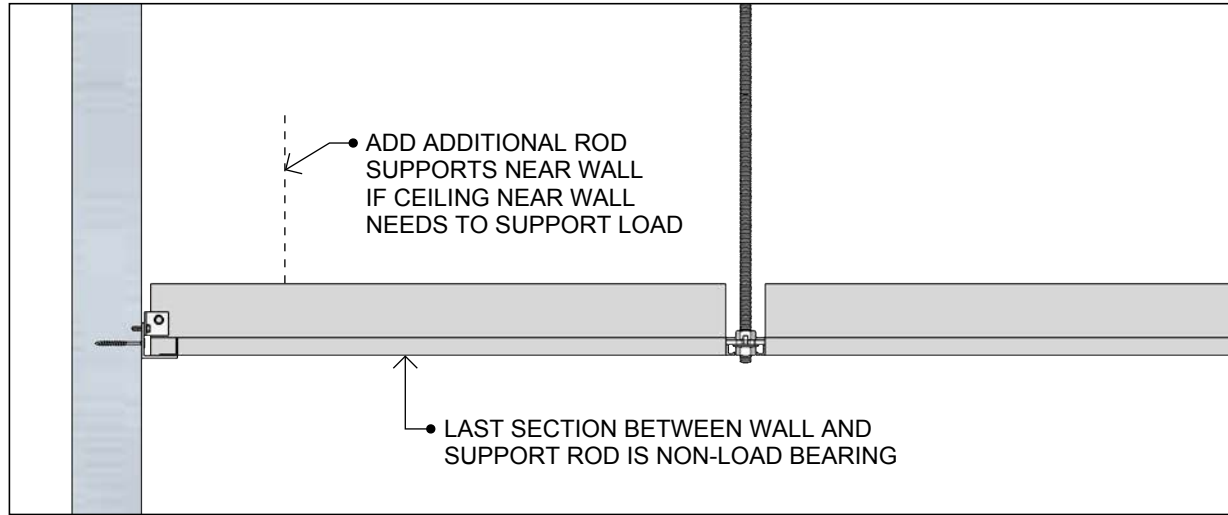

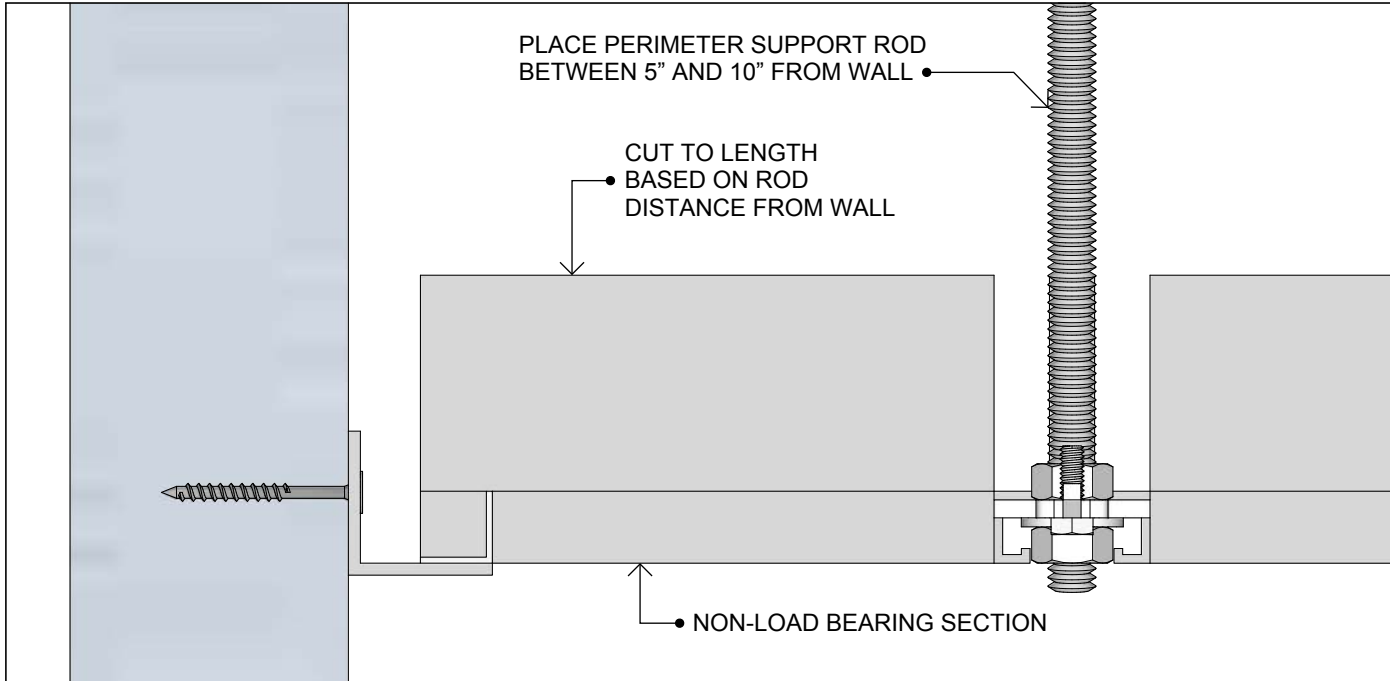
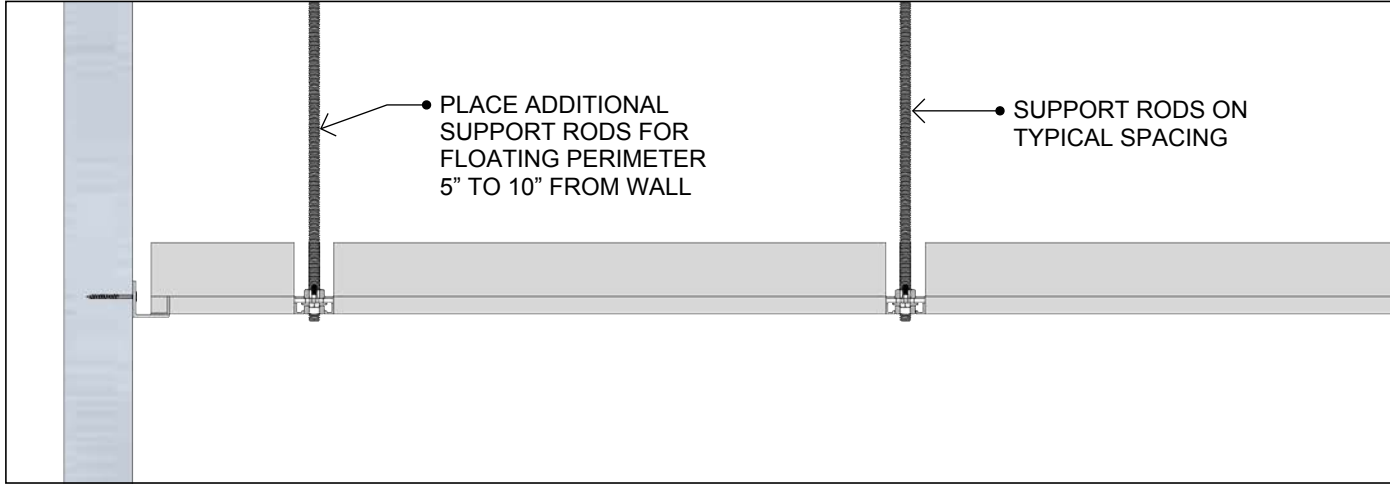

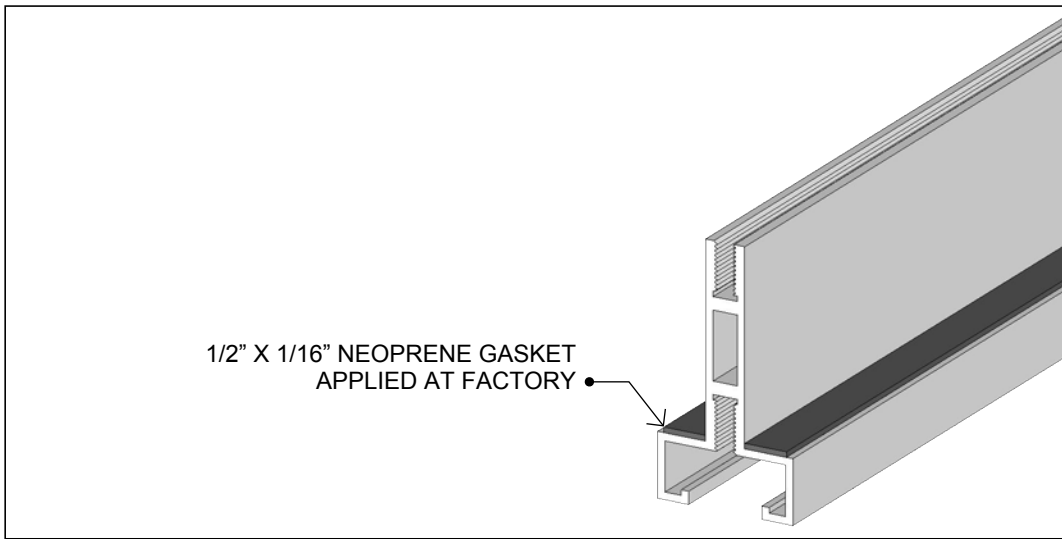
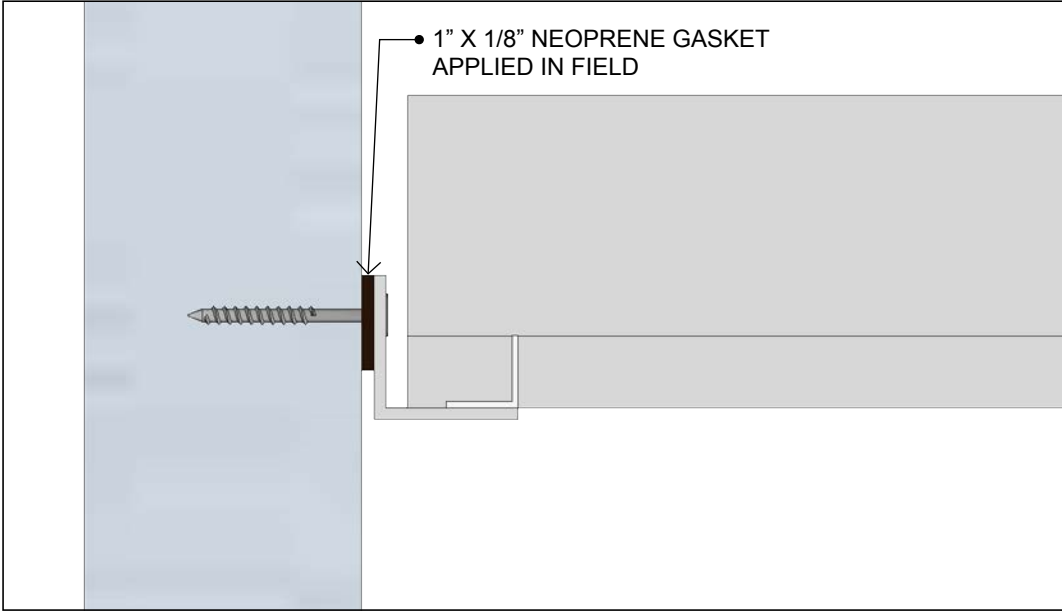

LAST MODIFIED
January 31, 2023

TITLE
GASKETING
WHEN SPECIFIED

PROJECT NAME
PICS GLOBAL
Structural Ceiling
Technical Drawing

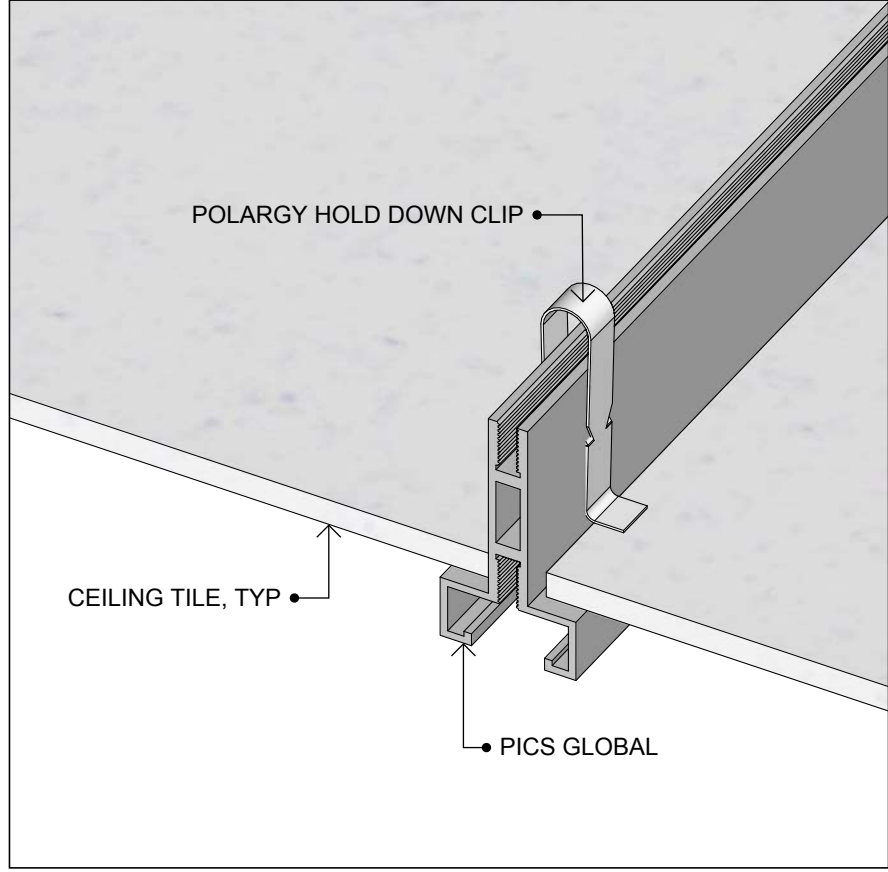

LAST MODIFIED
January 31, 2023

TITLE
HOLD DOWN CLIP

PROJECT NAME
PICS GLOBAL
Structural Ceiling
Technical Drawing